

TREATMENT OF SLUDGE FROM THE PARNABY PLANT OF M&TPP "UGLJEVIK" - REPUBLIC SRPSKA

Lazić Predrag¹, Deušić Slaven²

Abstract: Methods of coal cleaning in autogenous suspension, in Parnaby drum and hydrocyclones are, in recent years, getting more and more importance in countries of the former Yugoslavia (Serbia, Montenegro, Republika Srpska). The coal cleaning process has proven to be effective, especially for younger coals; it is quite simple, and in addition to that it is acceptably priced. As products of this process, obtained are clean coal (CC) sized -100(80)+0.5 mm, has tailings fractions of -100(80)+0.5 mm and sludge fractions of -0.5+0 mm. The treatment of sludge in the past (typically) involved its settling in the sedimentation facilities and discharge of the overflow water into the watercourses.

The latest trends which are in full compliance with environmental requirements imply different treatment of sludge from the Parnaby process. This treatment usually includes thickening and filtering of sludge with return of the overflow water from the thickeners back into the process, in the so-called closed cycle.

Key words: thickening, filtering, return water, closed cycle

1. INTRODUCTION

Coal cleaning plant at the open pit "Bogutovo Selo" - Ugljevik was built in 1997 and was designed by the Design Sector of the Research and Development Department of Viskoza - Razvoj company from Loznica (*Sektor za projektovanje – R.O. za istraživačko razvojne poslove, Viskoza razvoj, Loznica*). It was intended for cleaning of the coal from the first and second roof layers, and was based on principle of gravitational concentration of the autogenous suspension, in the Parnaby process. As a result of this coal cleaning procedure, obtained are clean coal fractions sized -100+0.5 mm and sludge fractions of -0.5+0 mm.

The design solution implies classifying of the clean coal in four size classes - chunk, die, nut and grain, and depositing it at the temporary depots from where it is dispatched to customers. Tailings are also temporarily stored in a dump from where they are shipped to the place of their final disposal.

The sludge is brought into the line of staged sedimentation tanks of which, currently, five stages have been built, with the overflow water going from each stage to the next one, and then, finally, into the waterways. Since the sludge contains clay particles and thus has low deposition speed, the process results in the overflow water

¹ University of Belgrade, Faculty of Mining and Geology, Dušina 7, 11000 Belgrade, Serbia,
e-mail: plazic@rgf.bg.ac.rs

² University of Belgrade, Faculty of Mining and Geology, Dušina 7, 11000 Belgrade, Serbia,
e-mail: sdeusic@rgf.bg.ac.rs

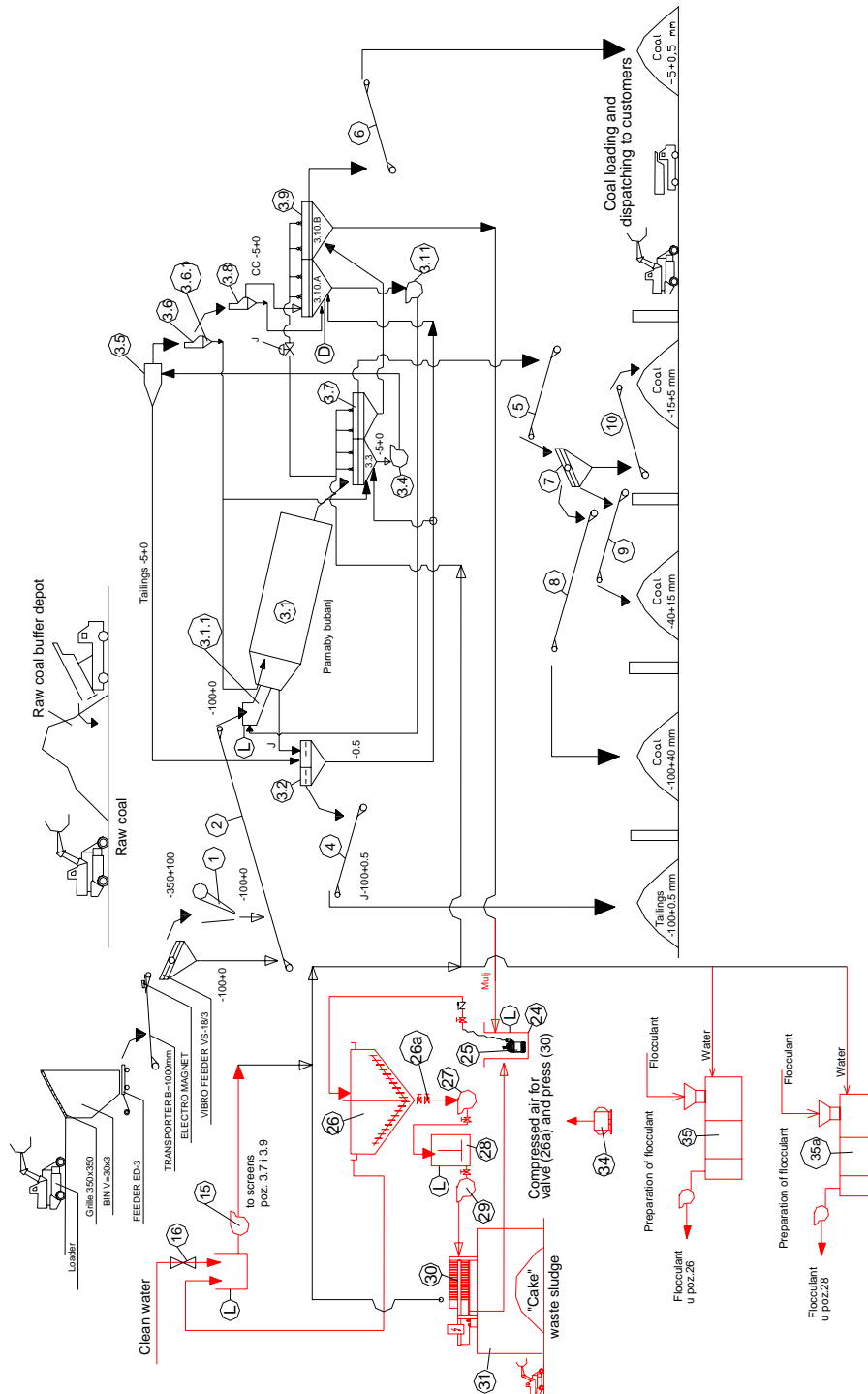

Figure 1 – Flowsheet of coal cleaning technology at the OP "Bogutovo Selo" Ugljevik

containing a higher proportion of suspended particles than needed for meeting the environmental criteria. As such treatment of sludge is inadequate the mine management has decided to appropriately solve this problem.

2. TECHNOLOGY OF COAL CLEANING IN AUTOGENOUS SUSPENSION

Along with the raw coal fractions sized $-100+0$ mm into an inclined drum with internal helix injected is an autogenous suspension of the appropriate density. Autogenous suspension runs down the drum, enhanced by the dynamic effect of the helix, carrying the light fraction (clean coal) with it. Tailings, being of denser composition, fall to the bottom of the drum and are carried upward, in the direction opposite to the flow of the suspension carrying the clean coal.

The light fraction, along with the suspension, comes out of the drum and is brought to a sieve with openings of 5 mm. Sifted output - grain-sized coal fraction ($-5+0$ mm) together with the suspension – is brought, by means of a bilge pump, to the battery of hydrocyclones where the cleaning of finer coal classes is performed. Clean coal fraction sized $-5+0.5$ mm goes through and over the two arched sieves, to a separate vibrating screen where a drip-off and washing of the clean coal are performed. Fine-grained tailings coming as hydrocyclone sand are merged with the coarse tailings. They go to a drip-off screen and are then transported, via a conveyor belt, to the tailings dump.

Clean coal fraction sized $-100+5$ mm goes to the rinsing sieve and then to the grading sieves producing an assortment of three classes: $-100+40$ mm, $-40+20$ mm and $-20+5$ mm, while the clean coal fraction sized $-5+0.5$ mm is transported, via a special conveyor belt, to the depot for this class.

Waste product of the process of coal cleaning in autogenous suspension is the suspension excess - sludge fraction sized $-0.5+0$ mm - which must be adequately treated in order for the environmental requirements to be met. Namely, in the existing technological process, the “treatment” of sludge represents its deposition in sedimentation facilities dug out in the terrain, while the overflow water containing a significant amount of suspended solids has been discharged into the watercourses.

3. OVERVIEW OF POSSIBLE WASTEWATER PURIFICATION TECHNOLOGIES

Since it is difficult to find reasons for the application of sedimentation facilities in the waste water purification technology within the wet coal cleaning and separation processes, the question is posed regarding their possible alternatives. Modern approaches to solving the waste water problem in wet coal cleaning and separation is the one of continuous purification with the ultimate goal of returning the liquid phase back to the technological process and obtaining a solid phase in a state suitable for transport and storage together with the coarse tailings. Although each technology has its own characteristics, they share the same principles that in their essence they include two technological operations: thickening and filtration.

3.1. Thickening

Very rarely the waste water of wet coal separation processes can be filtered without their prior densification. Clean coal that is a result of the cleaning process must first be flushed with large quantities of water under pressure (not less than $0.5 \text{ m}^3/\text{t}$ of material to be washed), thus causing a significant dilution of waste water.

Cylindrical Thickeners

Thickeners are the most widely used devices for densification in mineral processing. They are usually of cylindrical shape, with an emptying hole at the bottom through which the condensed sludge, under the slow continuous rotary action of rakes, is being emptied. More or less clear overflow is collected and conducted by a channel located at the top edge of the thickener.

The thickening can be accomplished with or without the use of flocculants. In general, the use of flocculants reduces the size of thickeners, that is, investment costs, but increases the operating costs. Sometimes the use of flocculants, due to the nature of a particular sludge, cannot be avoided, which also proved to be the case with the sludge from the Parnaby coal cleaning process from the OP "Bogutovo Selo".

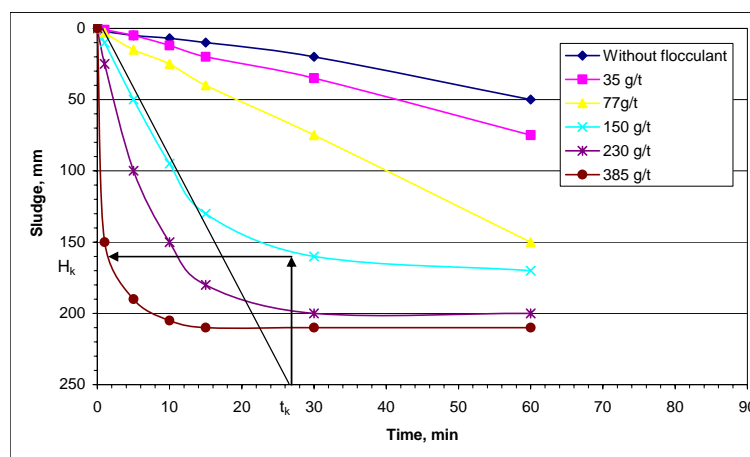

Figure 2 - Sedimentation curves of the sludge from the Parnaby process at the OP "Bogutovo Selo" - Ugljevik

The work of thickeners is based on gravitational sedimentation of the solid phase. Densification surface must be large enough to provide the time necessary for each of the particles to pass each of the densification zones and allow even the slowest particles to reach the bottom of the thickener. Also, it must be large enough to provide clear overflow. The thickeners are therefore required to either:

1. provide sand of the required density,
2. provide clear overflow, or
3. provide both clear overflow and the required density of output material.

Most often, one of the first two of the listed requirements is set. As for cleaning the waste water from the wet coal separations is concerned, the first requirement is the most common. The sludge must be condensed to the density required by the next stage of its processing (e.g. filtering), while for the rinsing of products of the coal cleaning process, it does not matter whether the return water contains 30 mg/l or 60 mg/l of solids.

One particular kind of cylindrical thickeners are the so-called **high capacity thickeners** (or *high rate thickeners*).

Very powerful flocculants enable so intense deposition of flocculated particles that the required densification surface in some cases plummets to 0.15 m²/t/day. In "ordinary" thickeners, the pulp is introduced at the top of the thickener and the solid particles slowly sink to the bottom where the thickening process is finalized. High capacity thickeners, schematically shown in Figure 3, are designed so that the waste water is introduced into the thickener closer to its bottom, directly into the zone of the dense pulp (pulp bed).

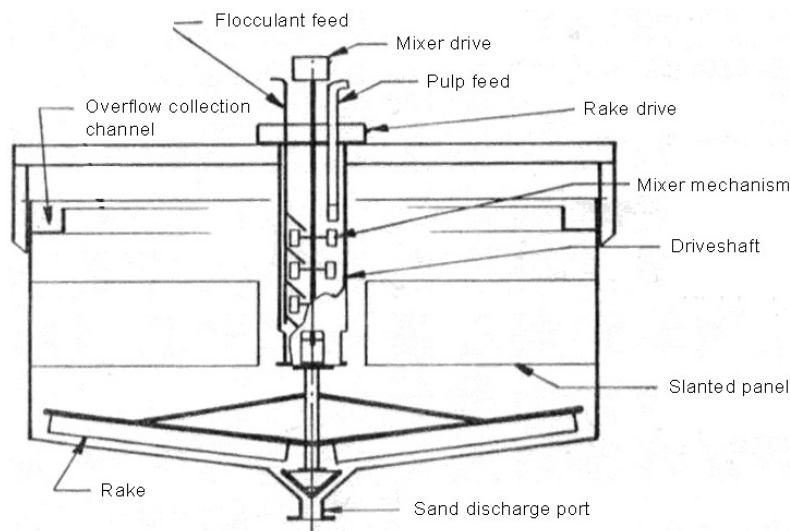

Figure 3 - High-rate thickener manufactured by Eimco company

Solid particles that have just been introduced in this layer are "caught", while the liquid phase begins its way upward, through the condensed material, thus being constantly filtered. The upper part of the dense pulp layer is held continuously in a fluidized state while the final thickening is performed in the lower part of the pulp bed.

The above presented high rate thickener technology offers a number of advantages in comparison to the conventional thickeners, which are as follows:

- higher capacity;
- smaller dimensions – the diameter of these thickeners is, for the same capacity, between the one third and one half of the classical thickener dimensions;

- better process control, as the smaller sized thickeners react faster to the process parameters change, enabling more precise automation control and minimizing of human involvement in process control;
- gives denser output sand, as the density of sand from the thickener is directly proportional to the amount of the flocculant added, the target density can be maintained by controlling the amount of flocculant;
- clean overflow, as injecting the waste water directly into the pulp bed ensures that even the smallest particles are not carried with the fluid into the overflow which thus typically contains between 20 do 50 ppm of suspended mater;
- low investment costs which are in the area of one half of investment that would be required for comparable conventional-type thickener;
- possibility of installation into enclosed spaces as their dimensions are significantly less, thus giving less dependence on climactic factors.

The drawback of high-rate thickeners is their need for usage of flocculant and the fact that they need it in amounts exceeding the ones needed for classic type thickeners.

3.2. Filtering

Filtering of waste water from the wet coal separation facilities has always been a separate and specific problem, primarily because of its usual high content of clay. Very successful procedures of filtering with disc or drum filters used for metal concentrates have proved to be unsuccessful for filtering of waste water from wet coal separation plants. Advancement in this area was made by introduction of centrifuges but it turned out very soon that, in addition to the exceptionally huge amounts of electrical energy they consumed (Fisher, Schill, 1981), they still did not produce the caked sludge that was dry and hard enough to be easily transported and deposited.

Separation of solid phase from the waste waters from the wet coal separation processes, after the process of thickening in various types of thickeners, is today performed mostly by three types of devices:

- horizontal belt filters;
- belt filter presses and
- filter presses.

Filter presses are especially efficient for sludge types dominated by clay particles sized 2-10 μm . With significantly higher pressures that are being used today (typically 50-60 bar instead of traditional 10-15 bar, filter presses are becoming very attractive for exceptionally heavy-duty conditions (Donhauser, 1995)

Filter Presses

Modern construction filter presses can provide pressures as high as 140 bar which is especially important for filtering of material with high contents of clay, such as the sludge from Parnaby coal cleaning technology. Filter press is designed for heavy-duty conditions and is suitable for filtering of metal mineral concentrates, coal and waste. It produces the cake with low moisture content, can have the capacity of up

to 250 t/h and is especially suitable for filtering of products whose particles are of size of several micrometers.

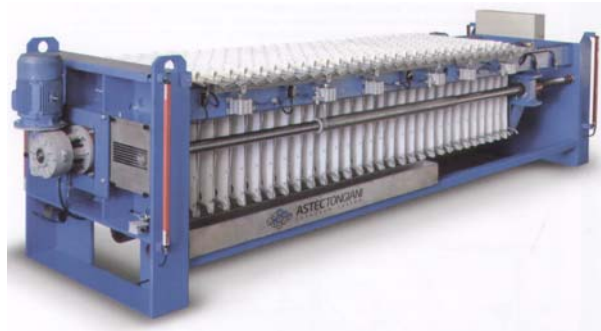

Figure 4 - Filter press manufactured by ASTEC-TONGIANI company

4. CONCLUSION

As the waste water produced in the Parnaby process of wet coal cleaning contains coal and tailings particles sized $-0,5+0$ mm for environmentally and technologically safe continuation of the plant's operation, a construction of waste water facility is needed in order that it does not reach the watercourses untreated.

Aware of the limitations of thus-far existent way of treatment of the waste water, the management of "Ugljevik" mine has decided to start a series of activities with the ultimate goal of modern, reliable, environmentally safe and economically feasible system for treatment of the waste water. Analysis presented in this paper represents a recapitulation of thus-far completed research in this area and it indicates the following:

- that there exist modern systems available for treatment of waste water, fulfilling the stated requirements regarding both the reliability and environmental safety;
- results obtained confirm successful use of densification agents (flocculants), without which the functioning of such contemporary systems for waste water processing is hardly practical.

This analysis pinpoints the requirements that the future waste water processing facility must fulfill:

- that the moisture content of the end product of waste water treatment must be such that it allows for easy manipulation, transport and disposition together with the coarse tailings;
- that the investments into equipment must be as low as possible;
- that the chosen technological process consumes as little electrical energy as possible;
- that the expenditure of flocculant, which represents the major share in operating costs, must be kept to a minimum;
- that the overall dimensions of this facility should be such as to allow its instalment in enclosed space.

These conditions can be met by the reconstructed plant. The reconstructed plant includes the complete existent Parnaby facility with the addition of thickeners, systems for flocculant supply and filters press for caked waste. The reconstruction will provide operation in closed cycle of waste water and therefore much lower consumption of fresh water. In addition to that, the filtered sludge will be produced in caked form, facilitating safe transport to the place of its final disposal.

REFERENCES

- [1] Cook, L.R., Childres, J.J., [1978]: *Trans AIME*, Vol 264.
- [2] Donhauser, F., [1995]: *New Developments in Dewatering of Clay*, Aufbereitungs-technik 36.
- [3] Đokić, S., Canić, M., [1989]: *Mogu li taložni bazeni rešiti problem otpadnih voda mokrih separacija uglja*, Rudarski glasnik 1/1989, Beograd.
- [4] Fisher, C.M., Schill, G.M., [1981]: *The dewatering of fine coal refuse with a continous high performance Belt filter press*.
- [5] Kong, D.L., [1978]: *Thickeners, Mineral Procossing Plant Design*, Published by Society of Mining Engineers of the American Institute of Mining, Metallurgical and Petroleum Engineers, New York.
- [6] Taraba, V., Marasová, D., [1997]: *Ekologická preprava uhlia, rúd, nerúd a iných materiálov*, Uhlí, Rudy, Geologický průzkum, No.1/1997, Česká, p.17-25, ISSN 1210-7697.
- [7] *The Sala Lamella Thickener*, Sala Information SIM 374.
- [8] [1994]: *Glavni tehnološko-mašinski projekat pogona za obogaćivanje uglja*, Viskoza razvoj, Loznica.
- [9] [1999]: *Tehnološke osnove projektovanja postrojenja za pripremu mineralnih sirovina*, Monografija, Rudarski institut, Beograd.
- [10] [2001]: *Studija čišćenja uglja iz rudnika "Ugljevik"*, Rudarski institut, Beograd.
- [11] [2006]: *Analiza postojećeg stanja sa predlogom rešenja otpadnih voda postrojenja za obogaćivanje uglja na P.K. "Bogutovo Selo" Ugljevik*, Ruding, Beograd.
- [12] [2007]: *Izveštaj o ispitivanju zgušnjavanja i filtriranja otpadne vode separacije uglja "Ugljevik"*, ITNMS, Beograd.
- [13] [2008]: *Analiza rada postrojenja za obogaćivanje uglja na P.K. "Bogutovo Selo" Ugljevik sa predlogom rešenja za tretman otpadnih voda*, Studija, Ruding, Beograd.
- [14] [2008]: *Studija izvodljivosti i isplativosti izgradnje dela postrojenja za tretman otpadnih voda iz Pranaby procesa čišćenja rovnog uglja sa PK "Bogutovo Selo" Ugljevik*, Ruding Princ's Son d.o.o., Nevesinje.
- [15] Prospektni materijal firme DELFILT Ltd. U.K.
- [16] Prospektni materijal firme PANNEVIS, Holandija.
- [17] Prospektni mateijal firme METSO MINERALS.