

## MEASURING METHODS FOR CROSS SECTIONS OF UNDERGROUND MINE CHAMBERS

Ganić Aleksandar<sup>1</sup>, Milutinović Aleksandar<sup>2</sup>, Tokalić Rade<sup>3</sup>, Ognjanović Saša<sup>4</sup>

**Abstract:** It is necessary to control form and size of cross sections at underground mine chambers both at the stage of chamber construction as well as periodically during its utilization. Deviation from design size or reduction of the section due to rock pressures may have very negative economic and safety consequences. Measuring of cross sections is performed by methods based on the application of classic instruments and tools, as well on the application of laser devices. This paper shows some of the most commonly used methods for measuring cross sections of underground mine chambers.

**Key words:** mine surveying, cross section, mine chamber

### 1. INTRODUCTION

Mining practice requires control of forms and sizes of cross sections at underground mine chambers. This is especially important in opening off chambers and development chambers, but also in main ventilating and conveying chambers. Reduced cross section of mine chamber below permissible limits specified for rail or belt conveying may represent potential cause of accidents and injuries of workers. Also, a more significant reduction of cross section may represent the cause of aggravated conditions of ventilation work site front and limiting factor while extracting mineral raw materials.

As regards the instruments and tools used while measuring cross sections of mine chambers, there are two methods:

- Method based on the usage of classic instruments and tools and
- Method based on the usage of laser devices.

### 2. CLASSIC METHODS FOR MEASURING CROSS SECTIONS IN MINE CHAMBERS

Several methods are used in surveying and measuring practice to control cross sections of mine chambers depending on their form and size (Borshch-Komponiets et al. 1989):

---

<sup>1</sup> University of Belgrade, Faculty of Mining and Geology, Dušina 7, 11000 Belgrade, Serbia,  
e-mail: aganic@rgf.bg.ac.rs

<sup>2</sup> University of Belgrade, Faculty of Mining and Geology, Dušina 7, 11000 Belgrade, Serbia,  
e-mail: amilutinovic@rgf.bg.ac.rs

<sup>3</sup> University of Belgrade, Faculty of Mining and Geology, Dušina 7, 11000 Belgrade, Serbia,  
e-mail: tokalic@rgf.bg.ac.rs

<sup>4</sup> PE for UEC Resavica, BCM "Jasenovac", Maršala Tita 33, 12316 Krepoljin, Serbia,  
e-mail: sasa.ognjanovic@jppeu.rs

- Method of direct measuring of mine chamber width and height,
- Measuring method by using two leveling staffs,
- Method of linear cut (arched section),
- Polar method, etc.

*Method of direct measuring* is one of the simplest and most commonly used ways to measure mine chambers of regular trapezoid or rectangular profile. In this way, total surface of chamber profile within rock massif can be determined without timberwork, as well as the daylight surface of cross section. For this purpose, total height of the chamber between roofing and flooring is to be measured, as well as the height between ridge board and upper edge of the rails; total width  $A$  and daylight width  $a$  of the ridge board; total width  $C$  and daylight width  $c$  at the altitude of tipping wagon; total width  $B$  and daylight  $b$  at flooring (Figure 1). Also, the distance between timberwork and tipping wagon, between the height of locomotive and contact wires is measured too, etc. The sizes measured are relatively oriented as regards the direction of mining works. The results of measurements and layout are recorded into the field book.

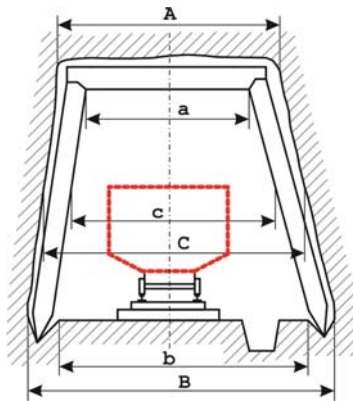

**Figure 1** - Method of direct measuring of cross sections

*Method of measurement of cross section by using two leveling staffs* (Figure 2) is mainly used in mine chambers with temporary railway transport.

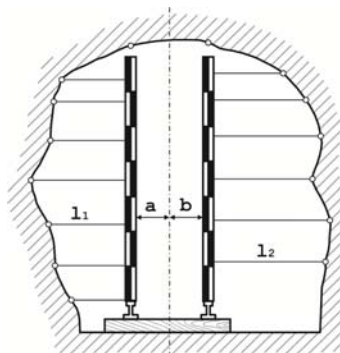
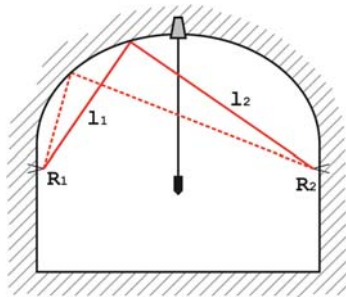

**Figure 2** - Method of measurement by using two leveling staffs

Measuring points are placed in the chamber at the distance of 1-5 m from each other and they are marked along the axis of mine chamber within flooring. Distances,  $a$  and  $b$ , are measured from the axis to leveling staffs that are placed vertically on rails. In intervals of 30 to 50 cm, horizontal distances between staffs and the left, i.e. right flank of mine chamber  $l_1$  and  $l_2$  are measured. The results of measurements are marked on layouts in the field book, and thereafter those sections are drawn in corresponding scale.

Cross sections of mine chambers with curvilinear or irregular form are measured by using patterns, by using method of arched section or by polar method.

*Method of arched section* is based on measurement of distances  $l_1$  and  $l_2$  from lateral benchmarks  $R_1$  and  $R_2$  to typical points at the outline of mine chamber (Figure 3).



Slika 3 - Method of arched section

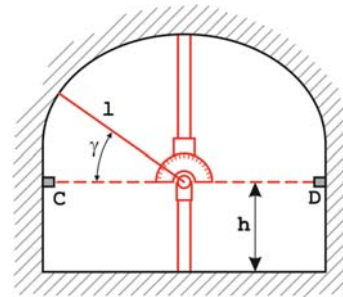

Slika 4 - Polar method

With *polar method*, measurements are made by using vertical protractor placed onto the corresponding telescopic stand (Figure 4). The procedure of measurement comprises of measurement of the distance  $l$  from the protractor's center to typical points at the perimeter of the mine chamber and elevation angles of the directions  $\gamma$  that can be read on the protractor.

Cross sections of mine chambers with height of 2-4 m can be measured by using Sopwith staffs.

Measurement of cross section of the mine chamber by using telescopic (sliding) staffs is shown in Figure 5. The plumb bob is to be placed along the direction marked by the person performing the measurement on a level with the desired cross section. The ribbon is to be rolled out and fixed in horizontal plane and it is used, among other, to determine the position of the plumb bob.

Sliding staff is placed at the corresponding distances in relation to the hand ribbon and the heights of mine chamber are measured by using it. Before each measurement, the perpendicularity of the staff is controlled by using the plumb bob attached to the staff itself. The intervals, within which the measurements by using staff are performed, depend on the complexity of the cross section of mine chamber. The results of measurement are marked on layouts in the field book.

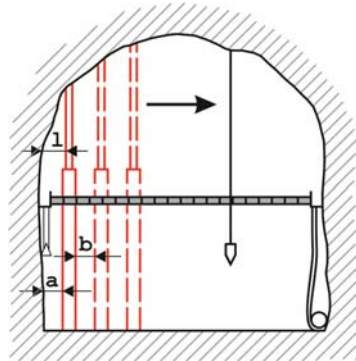

**Figure 5** - Measurement of cross sections of mine chambers with greater height

### 3. LASER METHODS FOR MEASUREMENT OF CROSS SECTIONS OF MINE CHAMBERS

Laser method for measurement of cross sections is based on the use of modern laser instruments, above all of laser total station, which measure the angles and lengths reflectorless and in the last years by using 3D laser scanners.

When using total stations for measurement of cross sections of mine chambers, the Leica system for measurements in tunnels and underground facilities, so called Leica TMS need to be specially mentioned (Tunnel Measurement System).

The Leica TMS consists of:

- A total station, class Leica TPS1100plus, which is, among others, characterized by:
  - Automatic profile measurement and marking of typical points due to reflectorless measurements,
  - Markings, that only one person can perform by using the Power Search command,
  - Wireless remote control unit RCS1100, which enables remote control of total station,
  - Sighting under conditions of very poor illumination due to the ATR system of automatic recognition of signal tags,
  - Project and measurement data transfer through PCMCIA card,
  - Possibility to be used, as motorized laser, for direction marking;
- Software support Leica TMS Office, that controls all measurement and marking data:
  - Defines and provides data import from the project,
  - Has interactive data and elements input from the project by using graphic on-line display,

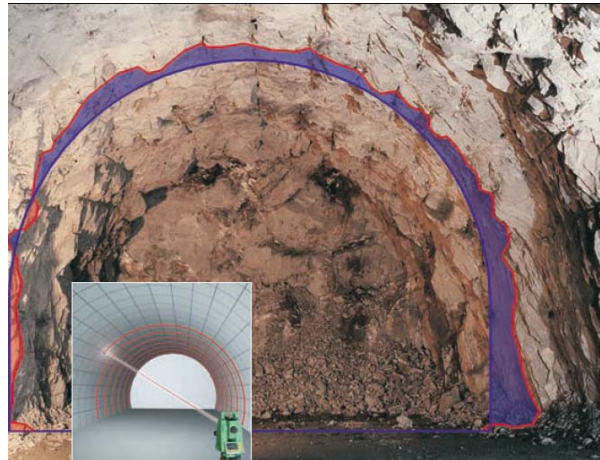

**Figure 6** - Measurement of cross sections by using total station (<http://www.leica-geosystems.us>)

- Defines complex groups of points and preparation of data for automatic marking,
- Hierarchical management of data for flexible editing of project data,
- User defined menu,
- Import/export of data in ASCII, DXF, GSI formats,
- PCMCIA card for exporting data into the total station,
- Calculation of distances between measured points and tunnel axes or some other typical directions,
- Calculation of the axis (regress line) of the sequence of recorded points, etc.

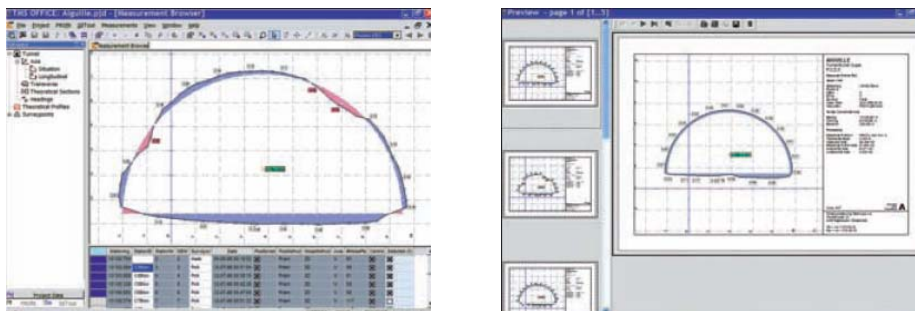

**Figure 7** - Control of cross sections by using Software Leica TMS Office (<http://www.amberg.ch>)

In the last ten years, the use of 3D laser scanners is more and more present in surveying and measuring practice. Those instruments enable very efficient gathering of information – detailed digital recordings on the shape and view of objects from the real world. Data gathered in this way are used for the development of 2D plans, cards, profiles or 3D models of scanned objects.

Digital recordings of the object – scans, obtained by 3D laser scanning, consist of a large number of points that have spatial  $X$ ,  $Y$  and  $Z$  coordinates. Those points are called the point cloud and, in one scan, there may be up to several million points. The field of sight of the scanner depends on the model, and with certain models it is  $360^\circ$  in horizontal and  $270^\circ$  in vertical plane.



**Figure 8** - Leica C10 scanner (<http://www.leica-geosystems.com>)

From the scanner's field of sight, objects or part of the object, that is to be scanned, is software-defined and the scan resolution is also defined. Horizontal and vertical distances between the adjacent points are defined by resolution, i.e. the density of point cloud is determined. Contemporary scanners enable gathering of very dense point cloud with distance from each other less than 1 mm. The speed of scanning depends on the scanner model and amounts up to 500,000 points per second.



**Figure 9** - Point cloud of the scanned tunnel (<http://www.gess.co.za>)

Laser 3D scanning represents very fast and flexible surveying system suitable for (Saal, 2009):

- Complete data gathering on cross and longitudinal sections, excavated volumes,
- Data base on the geometry as basic documentation of carried out status and future works,
- Control and analysis of single sections,
- Control of the status and measurements of deformations on the excavation front,
- Calculation of excavated masses,
- Comparison of two scanners for the purpose of spatial analysis,
- Control of cross sections after concrete works,
- Determination of the thickness of concrete layer of the support,
- Photo documentation of works, etc.

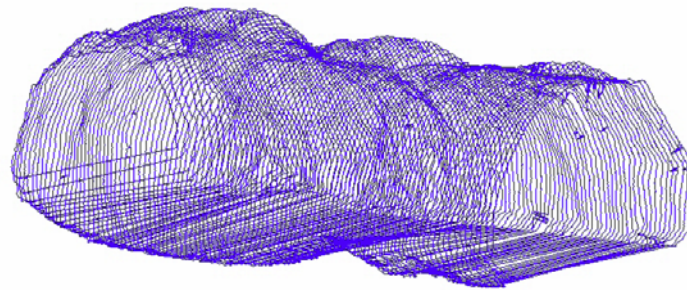

**Figure 10** - 3D model of the underground chamber

The advantages of this method are (Ackermann and Hunt, 2004):

- Minimum influence to working operations during measurement,
- In-situ results of the cross section control,
- Precise determination of excavated masses,
- Objective registration of the materials used,
- Possibility to scan with speed up to 130 m per hour,
- Comprehensive data base for optimal continuation of works,
- Complete data on the condition of chambers,
- Flexible work without additional infrastructural requests (for example illumination, power supply, additional control points, etc.).

#### **4. CONCLUSION**

Today, laser instruments and equipment rule the Geodesy and Mine surveying. Hence, laser-using methods for measuring cross sections in underground chambers are becoming increasingly present and represented. The reason for this is not only simpler, more efficient, faster and more precise obtaining of significantly larger number of measured data, but also the possibility of analysis, comparison and additional processing of the measurement results in the field itself, which is enabled by using software accompanying those laser devices.

The use of laser method of recording the cross and longitudinal sections and generally of underground mine chambers has, primarily, two limiting factors:

- Economic factor – high price of those devices, which for 3D laser scanner amounts to even more than 100,000 €,
- Safety factor – those devices have no methane protection so therefore they cannot be used in methane mines.

In view of the above, laser methods of recording are applied when constructing and controlling underground traffic and other infrastructural facilities, and they can be used in metal mines. For coal mines and methane pits, laser instruments may not be used, so measurements of cross sections of mine chambers there are carried out exclusively by using classical instruments and tools.

#### ACKNOWLEDGEMENT

This paper is the result of the Project No. 33029, which was financed by the funds of the Ministry of Education and Science of the Republic of Serbia.

#### REFERENCES

- [1] Ackermann, A.W., Hunt, C., (2004): *The Role of Digital Monitoring Technologies in the Development of Comprehensive Tunnel Maintenance Strategies*, [http://www.ctta.org/FileUpload/ita/2004/data/abs\\_b12.pdf](http://www.ctta.org/FileUpload/ita/2004/data/abs_b12.pdf) [Accessed 23/12/2010].
- [2] Borshch-Komponiets, V., Navitny, A., Knysh, G., (1989): *Mine Surveying*, Mir Publishers, Moscow.
- [3] Saal, K., (2009): *Tunneldrive Scanning with Leica HDS6000*, Leica Reporter 61, [https://portal.leica.com/enewsletters/enews5.4/Reporter\\_61\\_741802\\_6100.pdf](https://portal.leica.com/enewsletters/enews5.4/Reporter_61_741802_6100.pdf) [Accessed 18/12/2010].
- [4] *Leica ScanStation C10*, <http://www.leica-geosystems.com/downloads123/hds/hds/ScanStation%20C10/brochures> [Accessed 15/01/2011].
- [5] *Leica TMS – Tunnel Measurement System*, <http://www.leica-geosystems.us/common/shared/downloads/inc> [Accessed 15/01/2011].
- [6] *TMS Solution: Surveying for tunnelling professionals*, <http://www.amberg.ch/at/fileadmin/documents/Systems> [Accessed 15/01/2011].
- [7] <http://www.gess.co.za/Solutions/TunnelSolutions.aspx> [Accessed 15/01/2011].